



Project: _____
 Model: _____ Series #: _____
 Dealer: _____ Quantity#: _____
 Delivery address: _____ Date: _____

3 Door Commercial Grade Under Counter Refrigerator

Model#KTR-72B1

Features

- Precision ventilated refrigeration system keeps food fresh
- Electronic control system make it easy to adjust temperature set point and defrost frequency
- Self closing door with 90 degree stay open feature, locks and keys included
- Preinstalled heavy duty casters with brakes
- Removeable installation board makes it easy to access condenser coil for cleaning
- Stainless steel exterior and interior, guaranteed to last up to 10 years and beyond
- Paired with a durable copper coil evaporator, Westlake products are ensure surpassing 10 years of reliable performance
- 3 epoxy coated steel wire shelves, 90 lbs loading capacity each
- R290 hydro carbon refrigerant that has zero(0) ozone depletion potential(ODP) & three(3) global warming potential(GWP)



WARRANTY:

- 2 Years Parts and Labor
- 6 Years compressor (Additional 4 years parts only)
- Westlake is responsible for components failure but is not responsible for improper operation failure and artificial damage.



Conforms to UL&NSF-7 Standards





3 Door Commercial Grade Under Counter Refrigerator

Model#KTR-72B1

TECHNICAL DATA

SKU	WKTR-72B
Model	KTR-72B1
Temperature range	33°F~41°F
Refrigerant	R290
Defrosting	Auto Defrost
Power	215W
Exterior Dimension(WxDxH) inch	72*29.9*35.2
Interior Dimension(WxDxH) inch	67.7*19.9*24.8
Gross Weight(lb)	348
Net Weight(lb)	320
Packing Dimension(WxDxH) inch	74.2*31.1*38.4
Voltage/Phase/Hz	115V/1/60Hz
Amps	1.7A
Electrical Cord Length	98.4 inches

PLAN VIEW

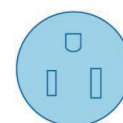
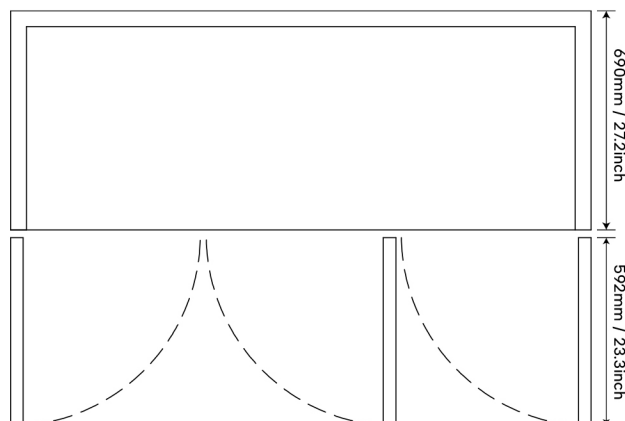
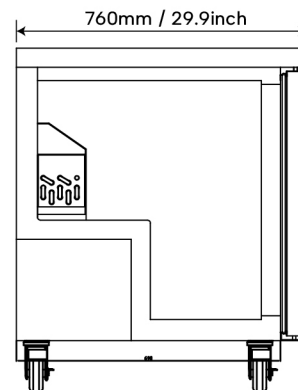
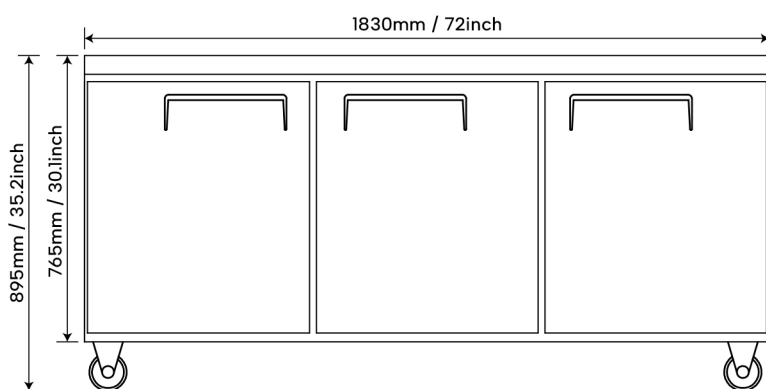

NEMA 5-15P