



WESTLAKE

Project: _____

Model: _____ Series #: _____

Dealer: _____ Quantity#: _____

Delivery address: _____ Date: _____

1 Door Commercial Grade Under Counter Freezer

Model#KTF-27B1



Features

- Precision ventilated refrigeration system keeps food fresh
- Electronic control system make it easy to adjust temperature set point and defrost frequency
- Self closing door with 90 degree stay open feature, locks and keys included
- Preinstalled heavy duty casters with brakes
- Removeable installation board makes it easy to access condenser coil for cleaning
- Stainless steel exterior and interior, guaranteed to last up to 10 years and beyond
- Paired with a durable copper coil evaporator, Westlake products are ensure surpassing 10 years of reliable performance
- 1 epoxy coated steel wire shelves, 90 lbs loading capacity each
- R290 hydrocarbon refrigerant that has zero(0) ozone depletion potential(ODP) & three(3) global warming potential(GWP)

WARRANTY:

- 2 Years Parts and Labor
- 6 Years compressor (Additional 4 years parts only)
- Westlake is responsible for components failure. but is not responsible for improper operation failure and artificial damage.



Parts & Labor



Compressor



Conforms to UL&NSF-7 Standards

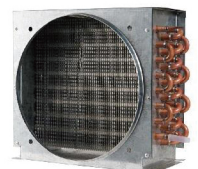



1 Door Commercial Grade Under Counter Freezer

Model#KTF-27B1

TECHNICAL DATA

| | |
|--------------------------------|----------------|
| SKU | WKTF-27B |
| Model | KTF-27B1 |
| Temperature range | -8°F~-0°F |
| Refrigerant | R290 |
| Defrosting | Auto Defrost |
| Power | 250W |
| Exterior Dimension(WxDxH) inch | 28.1*29.9*35.2 |
| Interior Dimension(WxDxH) inch | 23.8*19.9*24.8 |
| Gross Weight(lb) | 179 |
| Net Weight(lb) | 168 |
| Packing Dimension(WxDxH) inch | 30.3*31.1*38.4 |
| Voltage/Phase/Hz | 115V/1/60Hz |
| Amps | 2.4A |
| Electrical Cord Length | 98.4 inches |

PLAN VIEW

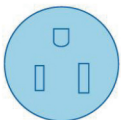
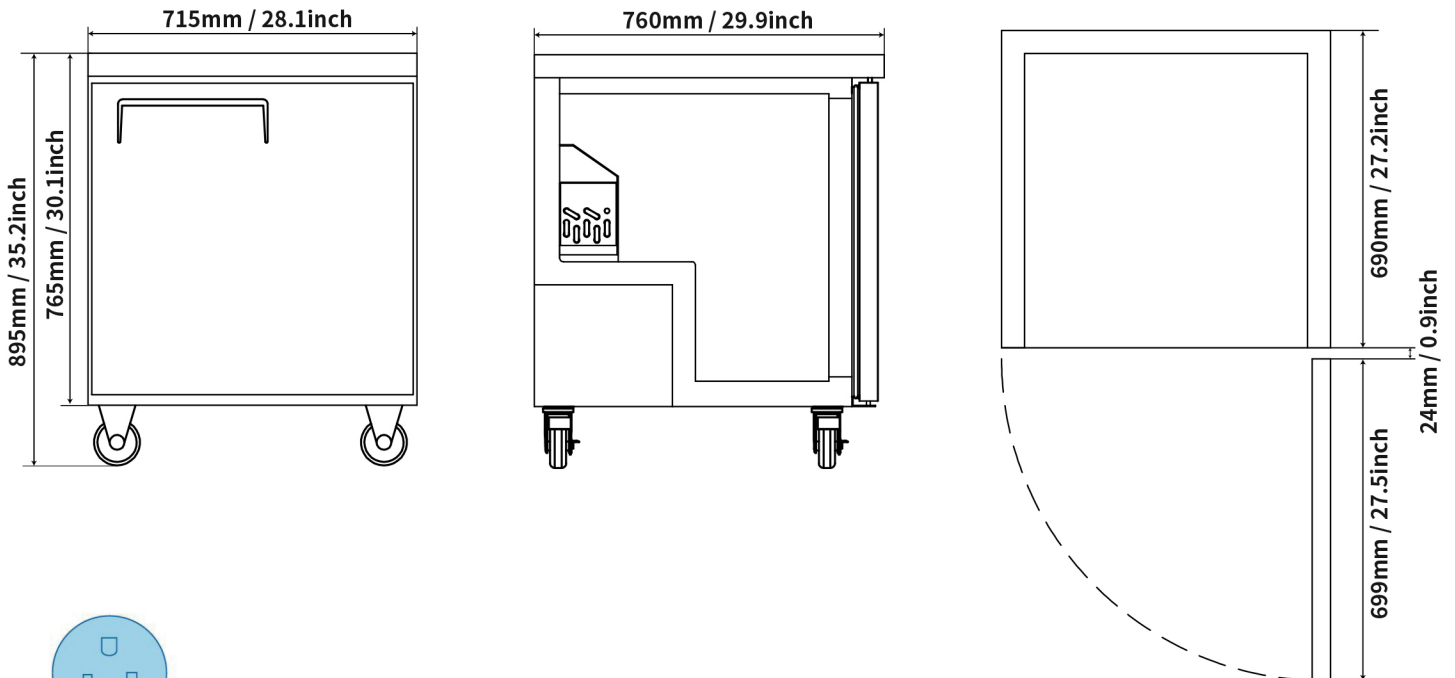

NEMA 5-15P