



Project: _____
 Model: _____ Series #: _____
 Dealer: _____ Quantity#: _____
 Delivery address: _____ Date: _____

Sandwich & Salad Food Prep Table Series 60'W

Model#KSR-60B1



Features

- Precision ventilated refrigeration system keeps food fresh
- Global famous electronic control system make it easy to adjust temperature set point and defrost frequency
- Self closing doors with 90 degree stay-open feature. Locks and keys included
- Stainless steel exterior and interior, guaranteed to last up to 10 years and beyond
- Removeable installation board makes it easy to access condenser coil for cleaning
- Paired with a durable copper coil evaporator, Westlake products are ensure surpassing 10 years of reliable performance
- Automatic defrost system and evaporate the defrosting water itself, no need extra discharging water pipe
- Four swivel preinstalled wheels, 2 of them with brakes

WARRANTY:

- 2 Years Parts and Labor
- 6 Years compressor (Additional 4 years parts only)
- Westlake is responsible for components failure. but is not responsible for improper operation failure and artificial damage.



Conforms to UL&NSF-7 Standards

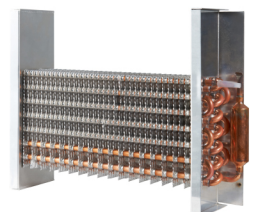



Sandwich and Salad Counter Food Prep Table Series

Model#KSR-60B1

TECHNICAL DATA

SKU	WKSR-60B
Model	KSR-60B1
Temperature range	33-41°F
Refrigerant	R290
Max Ambient Temperayure	100°F
Defrosting	Automatic every 4 hours
Horse power	1/2
Exterior Dimension(WxDxH)inch	60"Wx29 9/10"Dx42 2/5"H
Interior Dimension(WxDxH)inch	56"Wx25 1/5"Dx26 2/5"H
Gross Weight(lb)	377lbs
Net Weight(lb)	333lbs
Packing Dimension(WxDxH) inch	62 1/5"Wx32 3/10"Dx45 7/10"H
Voltage/Phase/Hz	115V/1/60Hz
Amps	3.2
Plug Type	NEMA 5-15P
Electrical Cord Length	80"
Food Pans included	1/6*16

PLAN VIEW

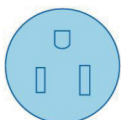
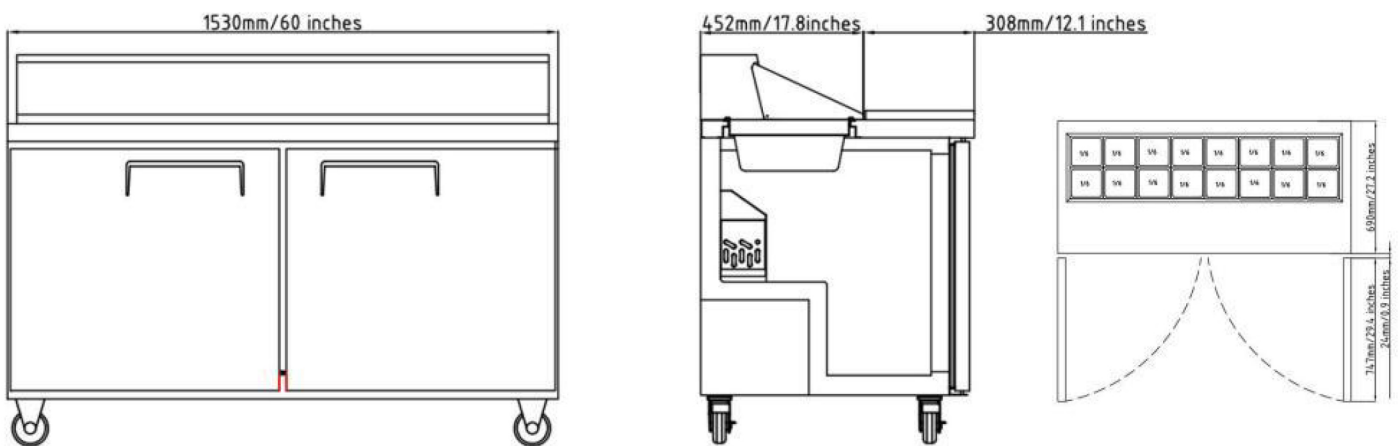

NEMA 5-15P