



WESTLAKE

Project: _____

Model: _____ Series #: _____

Dealer: _____ Quantity#: _____

Delivery address: _____ Date: _____

Mega Top Sandwich & Salad Food Prep Table Series 27'W

Model#KSR-27BM1

Features

- Precision ventilated refrigeration system keeps food fresh
- Global famous electronic control system make it easy to adjust temperature set point and defrost frequency
- Self closing doors with 90 degree stay-open feature. Locks and keys included
- Stainless steel exterior and interior, guaranteed to last up to 10 years and beyond
- Removeable installation board makes it easy to access condenser coil for cleaning
- Paired with a durable copper coil evaporator, Westlake products are ensure surpassing 10 years of reliable performance
- Automatic defrost system and evaporate the defrosting water itself, no need extra discharging water pipe
- Four swivel preinstalled wheels, 2 of them with brakes



WARRANTY:

- 2 Years Parts and Labor
- 6 Years compressor (Additional 4 years parts only)
- westlake is responsible for components failure. but is not responsible for improper operation failure and artificial damage.



Parts & Labor



Compressor



Conforms to UL&NSF-7 Standards

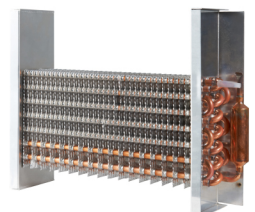



Sandwich and Salad Counter Food Prep Table Series

Model#KSR-27BM1

TECHNICAL DATA

SKU	WKS-27BM
Model	KSR-27BM1
Temperature range	33~41°F
Refrigerant	R290
Max Ambient Temperature	100°F
Defrosting	automatic every 4 hours
Horsepower	1/4HP
Exterior Dimension(WxDxH)inch	28.1*33.9*46
Interior Dimension(WxDxH)inch	24.2*23*24.6
Gross Weight(lb)	198
Net Weight(lb)	176
Packing Dimension(WxDxH) inch	30.3*33.8*50.4
Voltage/Phase/Hz	115V/1/60HZ
Amps	2.4
Plug Type	NEMA 5-15P
Electrical Cord Length	70.8"
Food Pans included	1/6*9+1/9*3
Cutting Board Dimension (WxDxH) inch	28.1*8.3*0.5

PLAN VIEW

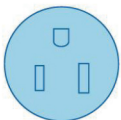
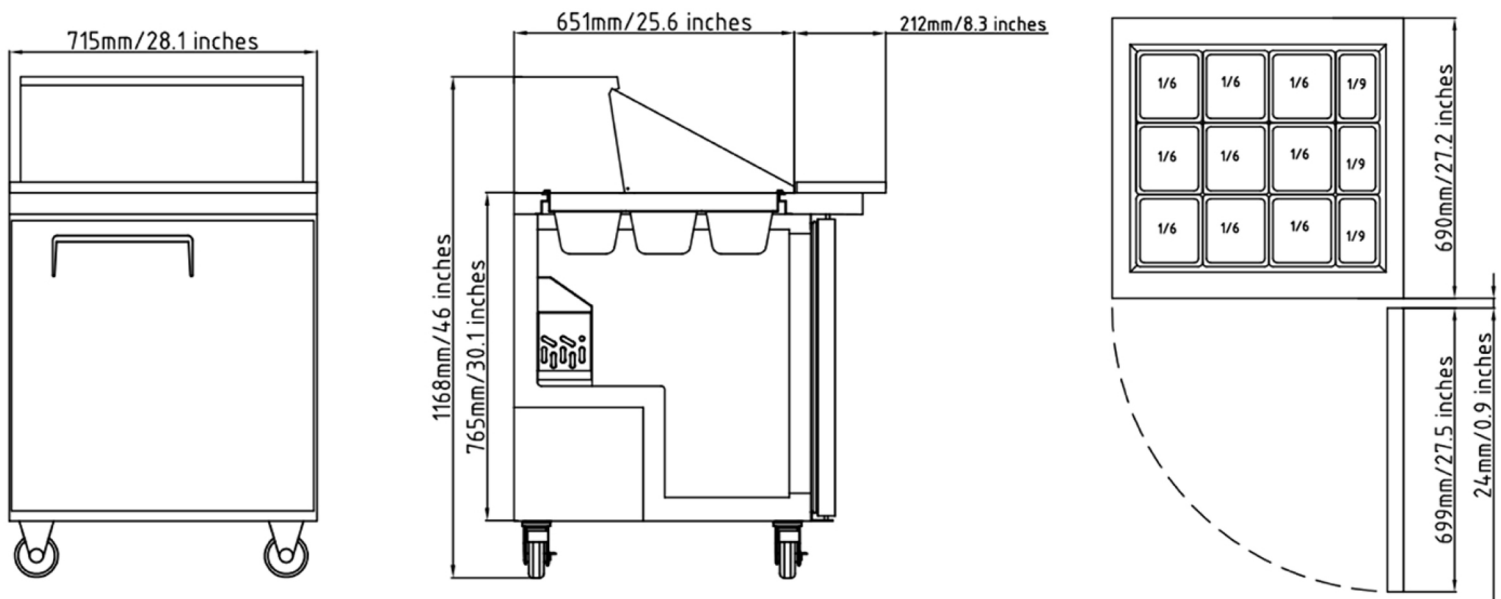

NEMA 5-15P